

T1 T2 T3.1 T3.2 T4.1 T4.2 locations on back side correspond to S1 S2 S3.1 S3.2 S4.1 S4.2 on front side

Note that all unique customer requirements (i.e tolerance) need to be verified thru Alfa Laval.

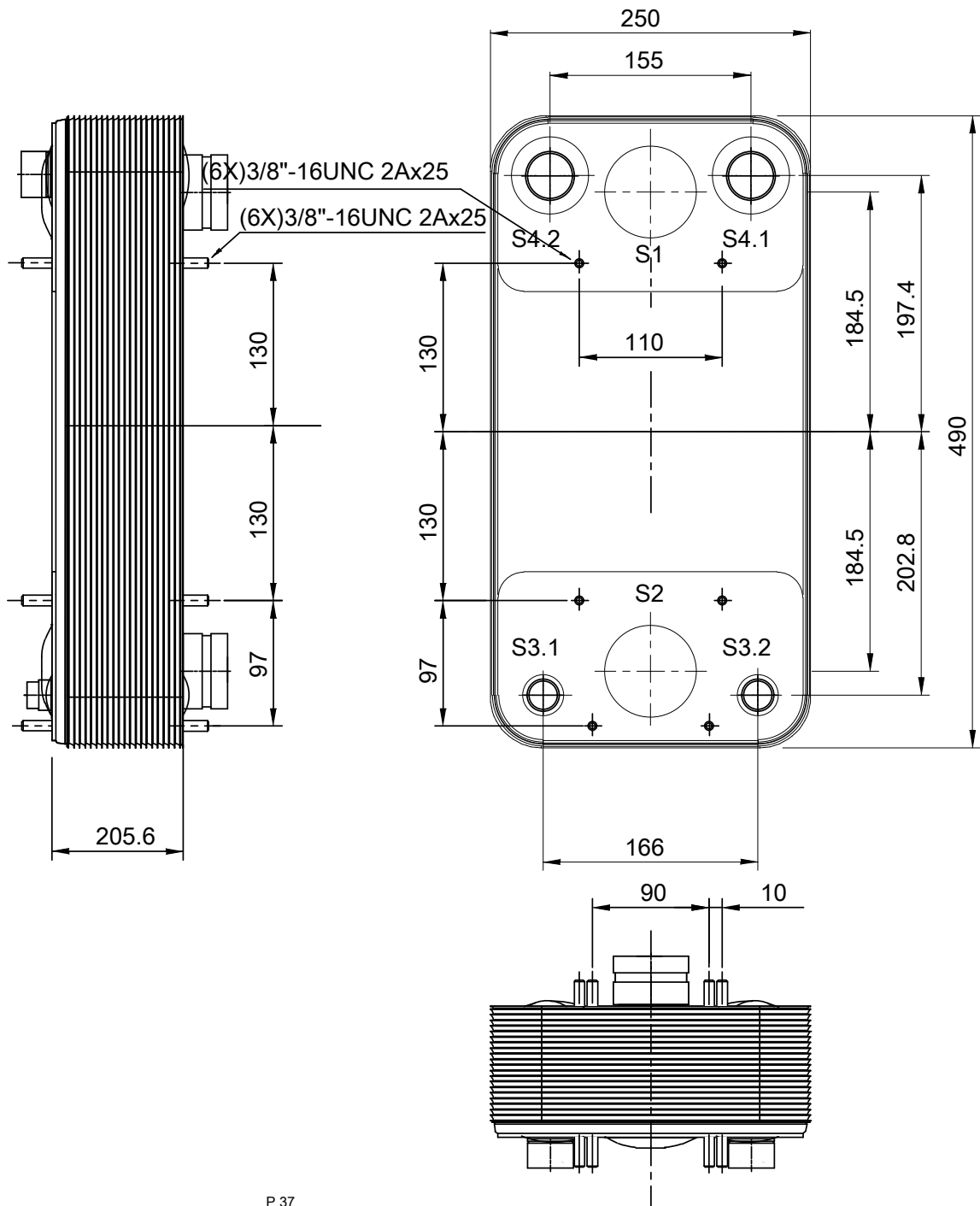
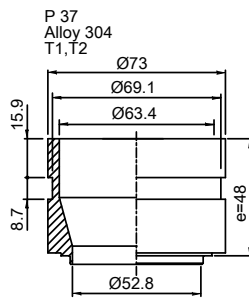
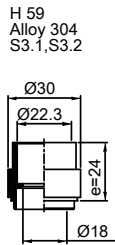
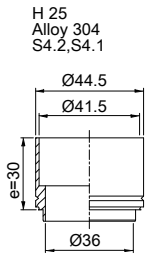

HEATING SURFACE
 NETWEIGHT 42.2 kg
 OPERATING WEIGHT
 PLATE MATERIAL Alloy 316
 PLATE GROUPING 1*44HR/1*45HB

ALL DIMENSIONS IN MILLIMETERS

SIDE	MEDIA	INLET	TEMP.	OUTLET	TEMP.	FLOW RATE	PRESSURE DROP	LIQUID VOL.
1								4.4 dm ³
2								4.4/4.4 dm ³



PRESSURE VESSEL APPROVAL UL/CRN
 ACH-230DQ-90H Y97 (3287084570)

www.alfalaval.com

CUSTOMER NAME / REF. NO.	TOTAL LENGTH	279.6 mm
	TOTAL WIDTH	250.0 mm
	TOTAL HEIGHT	490.0 mm
COMPANY / REF.		
		3/15/2017 REV 0