

Note that all unique customer requirements (i.e tolerance) need to be verified thru Alfa Laval.

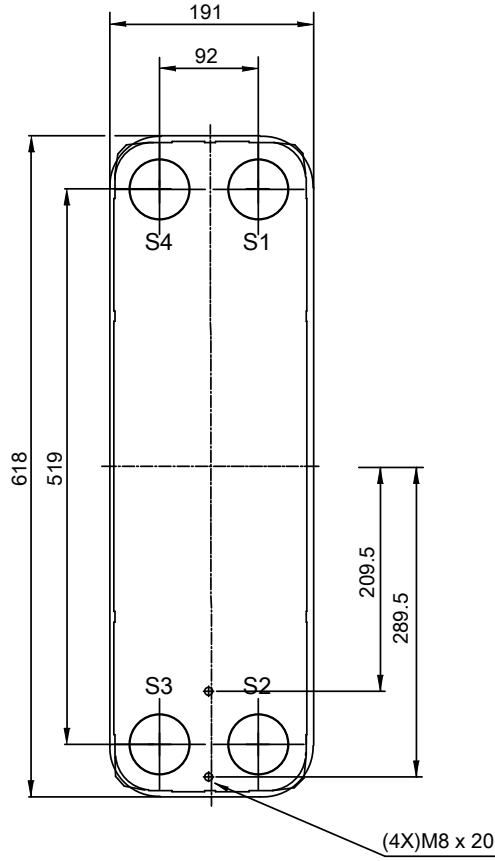
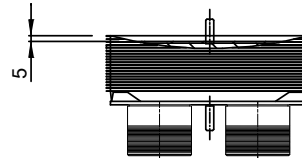
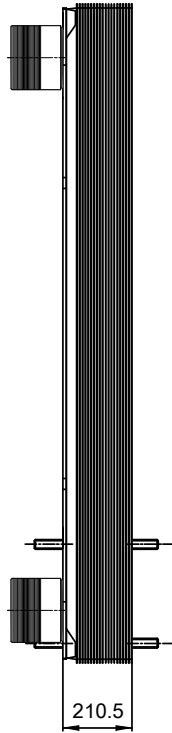
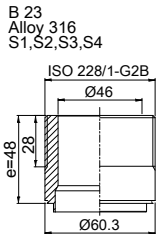

T1 T2 T3 T4 locations on back side correspond to S1 S2 S3 S4 on front side

HEATING SURFACE
 NETWEIGHT 51.3 kg
 OPERATING WEIGHT
 PLATE MATERIAL Alloy 316
 PLATE GROUPING 1*34H/1*35H

ALL DIMENSIONS IN MILLIMETERS

SIDE	MEDIA	INLET	TEMP.	OUTLET	TEMP.	FLOW RATE	PRESSURE DROP	LIQUID VOL.
1								8.5 dm ³
2								8.75 dm ³

PRESSURE VESSEL APPROVAL PED
 AlfaNova 76-70H (3287050294)



www.alfalaval.com

CUSTOMER NAME / REF. NO.	TOTAL LENGTH	278.5 mm
	TOTAL WIDTH	191.0 mm
COMPANY / REF.	TOTAL HEIGHT	618.0 mm
		8/24/2017 REV 0