

FRONT VIEW

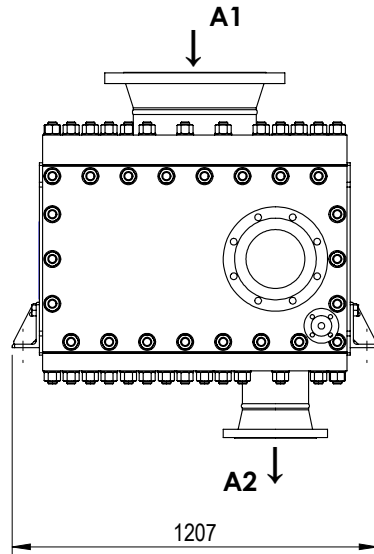

LEFT VIEW

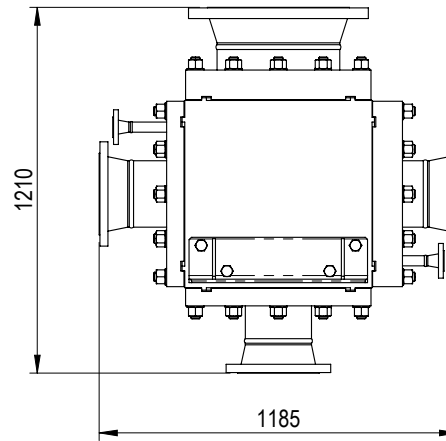

TOP VIEW

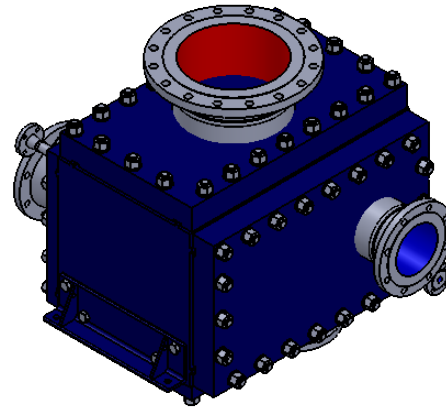
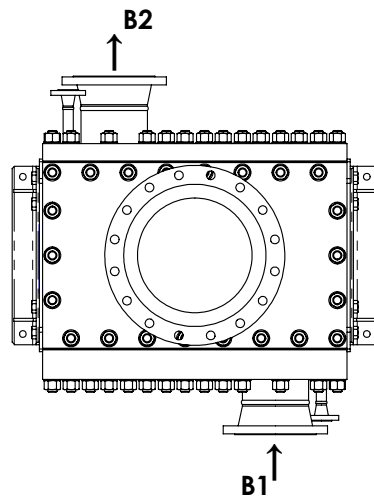

CONNECTIONS			
NAME	DN/NPS	PN / Class	SERVICE
A1	DN400	CLASS150	Inlet Process
A2	DN200	CLASS150	Outlet Process
B1	DN200	CLASS150	Inlet Cold Side
B2	DN200	CLASS150	Outlet Cold Side

VENT DRAIN		
NAME	DN/NPS	PN / Class
VA/DA	25	CLASS150
VB/DB	25	CLASS150

	SIDE A	SIDE B
Design Pressure	8.000 bar	8.000 bar
Max Temperature	200.0 °C	200.0 °C
Min Temperature	0.0 °C	0.0 °C
Plate Material	ALLOY 316 L	
Lining Material	ALLOY 316 L	ALLOY 316 L
Gasket Material	GRAPHITE	GRAPHITE
Net Weight	2616 kg	

* Please note that the Design Pressure is considered to be identical to the MAWP.
Any over-thickness in the calculation note or/and on the 'as-built' exchanger will not be considered in a re-calculation aimed at adjusting the MAWP.

Data, spécification, and other kind of information of technological nature set out in this document and submitted by Alfa Laval to you ("Proprietary Information") are intellectual proprietary rights of Alfa Laval. The Proprietary Information shall remain the exclusive property of Alfa Laval and shall only be used for the purpose of evaluating Alfa Laval's quotation. The Proprietary Information may not, without the written consent of Alfa Laval, be used or copied, reproduced, transmitted or communicated or disclosed in any other way to a third party.

Item : 5bar steam 200m3 125C

Setting : Horizontal

Sheet scale : 1:25

All dimensions are stated in mm



COMPABLOC HEAT EXCHANGER

CP50



Note : Hydrostatic tests will be performed with liners installed, no pressure retaining welds will be leak tested before liners are installed