

Note that all unique customer requirements (i.e tolerance) need to be verified thru Alfa Laval.

H 34  
Alloy 304  
S4

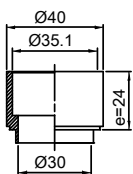

H 38  
Alloy 304  
S1,S2

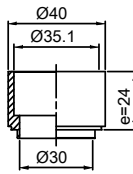

G 68  
Alloy 304  
S3

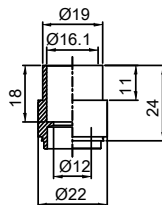

HEATING SURFACE  
NETWEIGHT 14.1 kg  
OPERATING WEIGHT  
PLATE MATERIAL Alloy 316  
PLATE GROUPING 1\*30ML/1\*31MH

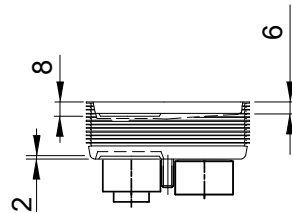
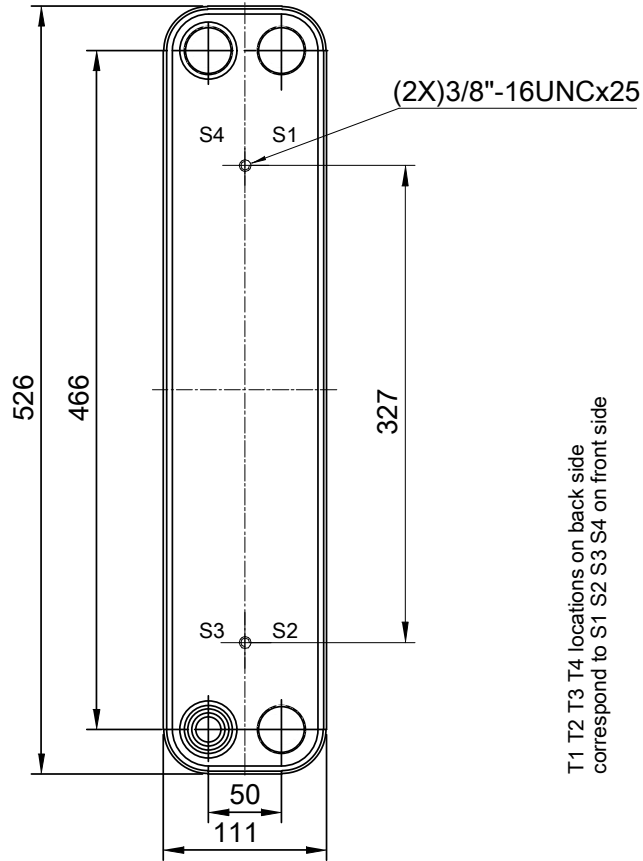
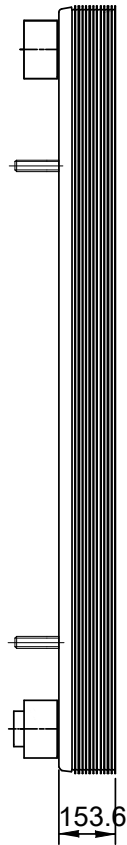

T1 T2 T3 T4 locations on back side correspond to S1 S2 S3 S4 on front side

ALL DIMENSIONS IN MILLIMETERS

SIDE	MEDIA	INLET	TEMP.	OUTLET	TEMP.	FLOW RATE	PRESSURE DROP	LIQUID VOL.
1								2.85 dm <sup>3</sup>
2								2.94 dm <sup>3</sup>

PRESSURE VESSEL APPROVAL

UL/CRN

ACH-70X-62M S25 (3287083723)

www.alfalaval.com

CUSTOMER NAME / REF. NO.

TOTAL LENGTH 179.6 mm  
TOTAL WIDTH 111.0 mm  
TOTAL HEIGHT 526.0 mm

COMPANY / REF.

6/5/2017  
REV 0