

Note that all unique customer requirements (i.e tolerance) need to be verified thru Alfa Laval.

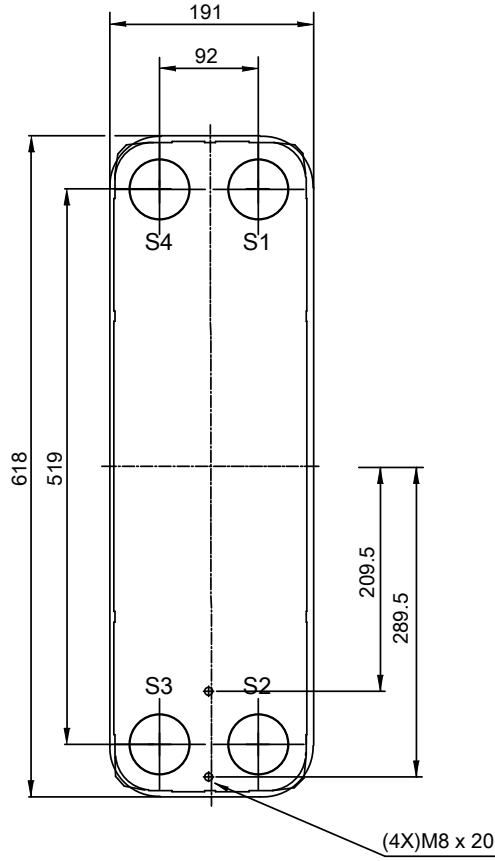
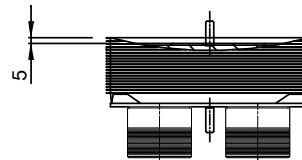
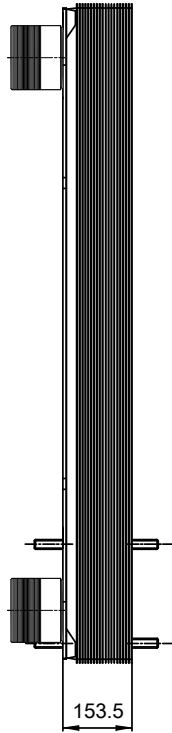
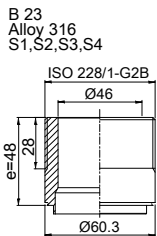

T1 T2 T3 T4 locations on back side correspond to S1 S2 S3 S4 on front side

HEATING SURFACE  
 NETWEIGHT 38.6 kg  
 OPERATING WEIGHT  
 PLATE MATERIAL Alloy 316  
 PLATE GROUPING 1\*24H/1\*25H

ALL DIMENSIONS IN MILLIMETERS

SIDE	MEDIA	INLET	TEMP.	OUTLET	TEMP.	FLOW RATE	PRESSURE DROP	LIQUID VOL.
1								6 dm <sup>3</sup>
2								6.25 dm <sup>3</sup>

PRESSURE VESSEL APPROVAL

PED



AlfaNova 76-50H (3287050293)

www.alfalaval.com

CUSTOMER NAME / REF. NO.

TOTAL LENGTH 221.5 mm  
 TOTAL WIDTH 191.0 mm  
 TOTAL HEIGHT 618.0 mm

COMPANY / REF.



8/24/2017  
 REV 0