

APPROXIMATE WEIGHTS:

TOTAL WEIGHT OF EMPTY DECANTER.....	375 kg / 825 lbs
ROTATING ASSY INCL. PILLOW BLOCKS.....	130 kg / 290 lbs
COMPLETE FRAME ASSY EXCL. MAIN MOTOR AND ROT. ASSY..	160 kg / 352 lbs
MAIN MOTOR.....	73 kg / 160 lbs
UPPER CASING.....	24 kg / 53 lbs
GEAR BOX.....	20 kg / 44 lbs

MIN. CRANE CAPACITY FOR LIFTING OF ROTATING ASSEMBLY: 150 kg / 330 lbs

LOADING DATA:

1. MAX. STATIC LOAD

A-VERTICAL.....	3500 N
B-HORIZONTAL.....	0 N

2. MAX. DYNAMIC LOAD AT RUN DOWN

(ADD TO STATIC LOAD)

A-VERTICAL.....	±1000 N
B-HORIZONTAL.....	± 500 N

3. MAX. DYNAMIC LOAD AT OPERATING SPEED

A-VERTICAL.....	±100 N
B-HORIZONTAL.....	±100 N

ALL LOADS ARE EVENLY DISTRIBUTED ON THE VIBRATION ISOLATORS

CONNECTION:

DIMENSION/TYPE

A FEED.....	Ø25.4 (1") HOSE CONNECTION
B SOLIDS OUTLET.....	RECTANGULAR FLANGE
*B SOLIDS OUTLET.....	173 x 363
C LIQUID OUTLET.....	RECTANGULAR FLANGE
*C LIQUID OUTLET.....	Ø75 HOSE CONNECTION
D POLYMER ADDITION.....	Ø12.7 (1/2") HOSE CONNECTION

NOTES:

1. ALL CONNECTIONS MUST BE FLEXIBLE.
2. FOR PROPER VENTING OF DISCHARGE HOPPERS REFER TO THE INSTALLATION DRAWING. IMPROPER VENTING CAN LEAD TO LEAKAGE PROBLEMS.
3. CUSTOMER IS RESPONSIBLE FOR ANCHORING.
4. FOR FURTHER INFORMATION, SEE INSTALLATION DATA MANUAL AND INSTALLATION DRAWING.

* OPTIONAL EQUIPMENT

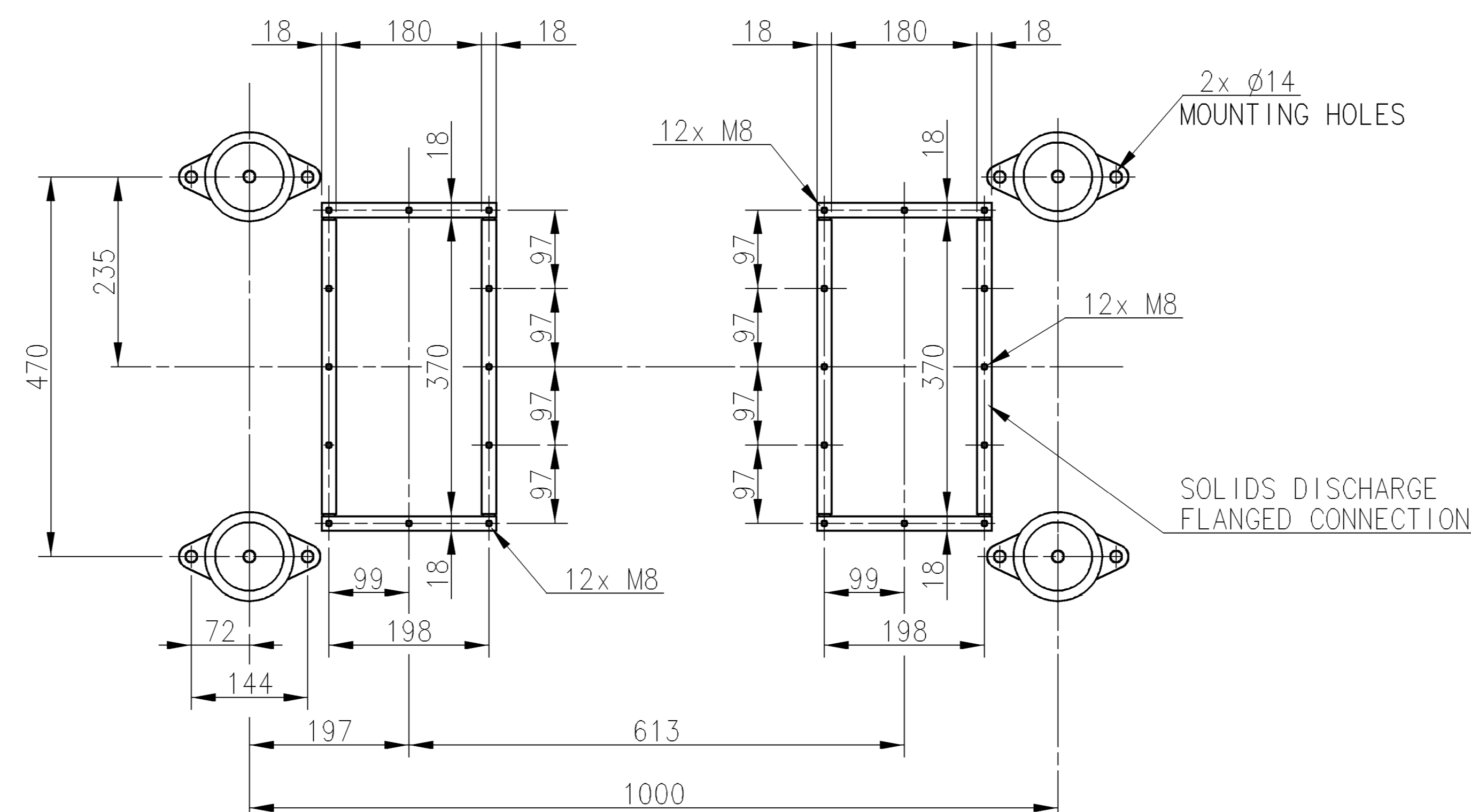

This document and its contents are the exclusive property of Alfa Laval and are not to be distributed, copied, or used for any purpose other than that intended by Alfa Laval.

Rev. No.	Date	Modified By	Appr.

Item	Article No.	Name/Designation	Material
0.4 kWh		GEAR BOX	
Title			
DIMENSIONED DRAWING			Alfa Laval
ALDEC 10			Alfa Laval Copenhagen A/S SØBORG DENMARK
First angle projection	Scale	Sheet	Date
RA/UM	1:5	GKU	080402
Format	Drawn	Appr.	Model
A0	DFa	KBSA	N
Document No.			61242306