

Note that all unique customer requirements (i.e tolerance) need to be verified thru Alfa Laval.

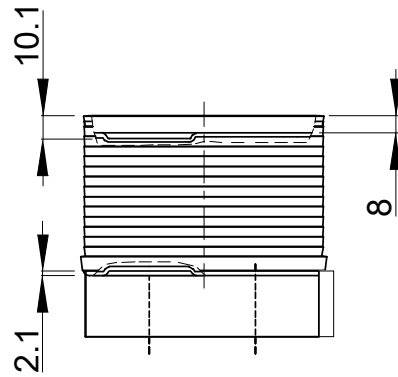
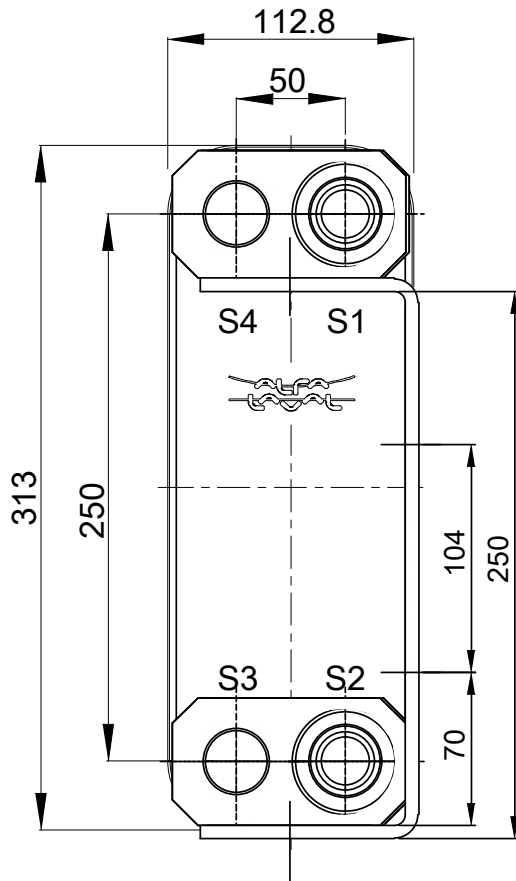
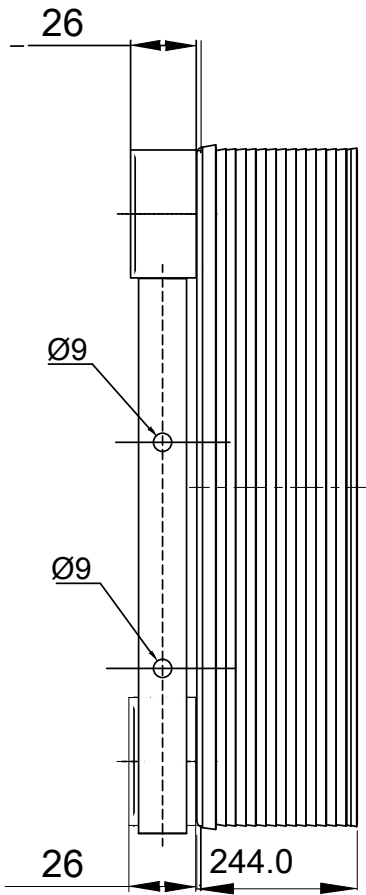

T1 T2 T3 T4 locations on back side correspond to S1 S2 S3 S4 on front side

ALL DIMENSIONS IN MILLIMETERS

SIDE	MEDIA	INLET	TEMP.	OUTLET	TEMP.	FLOW RATE	PRESSURE DROP	LIQUID VOL.
1								2.65 dm ³
2								2.7 dm ³

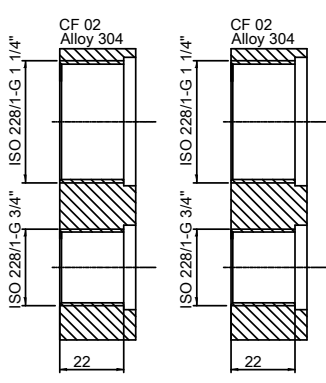

HEATING SURFACE
 NETWEIGHT 14.3 kg
 OPERATING WEIGHT
 PLATE MATERIAL Alloy 316
 PLATE GROUPING 1*49H/1*50H



PRESSURE VESSEL APPROVAL PED
 DOC30-100H (3287083349)

www.alfalaval.com

CUSTOMER NAME / REF. NO.	TOTAL LENGTH	270.0 mm
	TOTAL WIDTH	113.0 mm
COMPANY / REF.	TOTAL HEIGHT	313.0 mm
		8/24/2017 REV 0